

# SE7200 Series Installation Guide

Install Guide for Low Voltage Zoning Room Controller

For Commercial HVAC Applications



## CONTENTS

<b>Installation</b>	<b>2</b>
Preparation	2
Location	2
Installation	2
<b>Terminal, Identification and Function</b>	<b>3</b>
Wiring	3
Main outputs wiring	4
Typical applications	4
Remote sensor accessories	7
<b>Configuring and Status Display Instructions</b>	<b>9</b>
Status display	9
<b>User interface</b>	<b>11</b>

## INSTALLATION

### Preparation

- Remove security screw on bottom of Room Controller cover.
- Open unit by pulling on bottom side of Room Controller (Figure 1).
- Remove wiring terminals from sticker.
- Read the FCC ID and IC label installed in the cover.

### Location

1. Should not be installed on an outside wall.
2. Must be installed away from any direct heat source.
3. Should not be installed near air discharge grill.
4. Should not be affected by direct sun radiation.
5. Nothing should restrict vertical air circulation to Room Controller.

### Installation

1. Swing open Room Controller PCB to left by pressing PCB locking tabs (Figure 2).
2. Pull out cables 6" out from wall. Ensure wall surface must be flat and clean.
3. Insert cable in central hole of base.
4. Align base and mark location of two mounting holes on wall ensuring base is in the proper orientation. Arrow on base should be facing up.
5. Install anchors in wall.
6. Insert screws in mounting holes on each side of base (Figure 2).
7. Gently swing back circuit board on base and push until tabs lock.
8. Strip each wire 1/4 inch from end.
9. Insert each wire according to wiring diagram.
10. Gently push excess wiring back into hole (Figure 3).
11. Re-Install wiring terminals in correct locations (Figure 3).
12. Re-install cover (top side first) and gently push extra wire length back into hole in wall.
13. Install security screw.

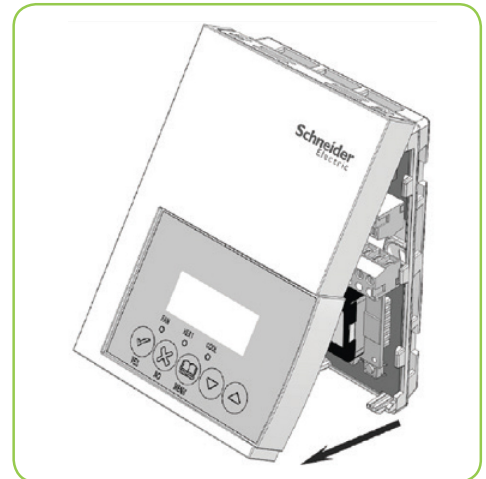

Figure-1 Open the cover

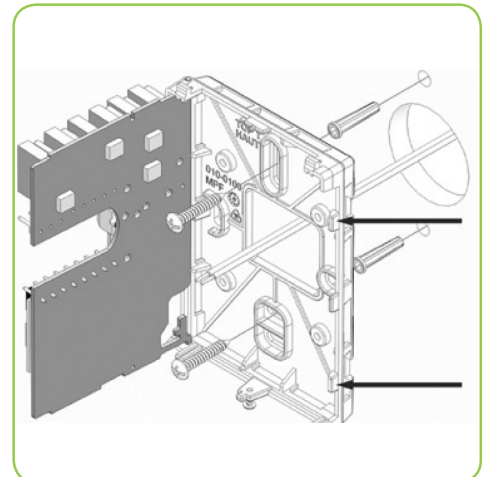

Figure-2 Location of PCB locking tabs

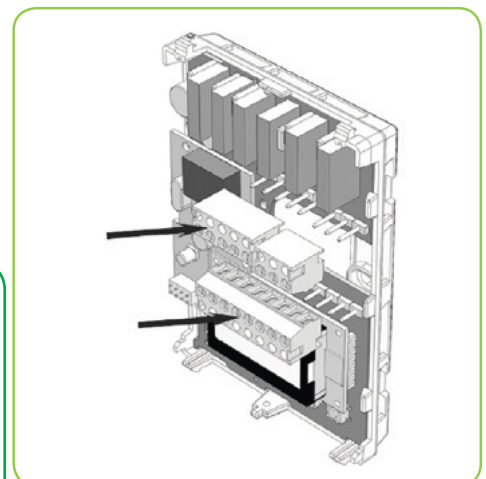

Figure-3 Re-install terminal blocks



If replacing an old Room Controller, label the wires before removal of the old Room Controller.

Electronic controls are static sensitive devices. Discharge yourself properly before manipulating and installing the Room Controller.

- A short circuit or wrong wiring may permanently damage the Room Controller or the equipment.
- All SE7000 series Room Controllers are designed for use as operating controls only and are not safety devices. These instruments have undergone rigorous tests and verification prior to shipping to ensure proper and reliable operation in the field. Whenever a control failure could lead to personal injury and/or loss of property, it becomes the responsibility of the user / installer / electrical system designer to incorporate safety devices (such as relays, flow switch, thermal protections, etc...) and/or an alarm system to protect the entire system against such catastrophic failures. Tampering with the devices or unintended application of the devices will result in a void of warranty.

## TERMINAL, IDENTIFICATION AND FUNCTION

### Terminal identification

Schneider Part Numbers Description / Application	SE7200C5x45(x) 1 or 2 Floating outputs 1 or 2 On/Off outputs	Viconics Number Description / Application	SE7200F5x45(x) 1 or 2 Analog outputs
4- 24 V~ Hot 5- 24 V~ Com	24 V~ Hot 24 V~ Com	4- 24 V~ Hot 5- 24 V~ Com	24 V~ Hot 24 V~ Com
6- Aux BO 5 7- Aux BO 5 8- BO 3 Open Heat	BO 5-Aux BO 5-Aux BO 3	6- Aux BO 5 7- Aux BO 5	BO 5-Aux BO 5-Aux
9- BO 4 Close Heat 10- BO 1 Open Cool 11- BO 2 Close Cool 12- BI 1 13- RS 14- Scom 15- BI 2 16- UI 3 COS / COC /SS	BO 4 BO 1 BO 2 BI 1 RS Scom BI 2 UI 3	9- AO 2 Heat 10- AO 1 Cool Not used Blank 12- BI 1 13- RS 14- Scom 15- BI 2 16- UI 3 COS / COC /SS	AO 2 AO 1 Blank BI 1 RS Scom BI 2 UI 3

### Wiring

#### Remote inputs ( All models )

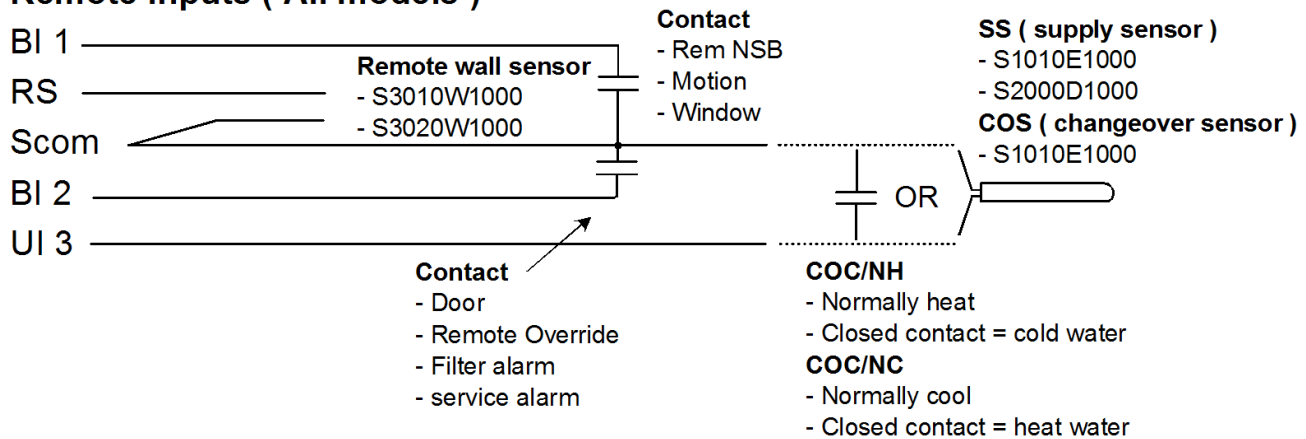

#### Auxiliary output ( All models )

- Dry contact to end device 24 V~ maximum

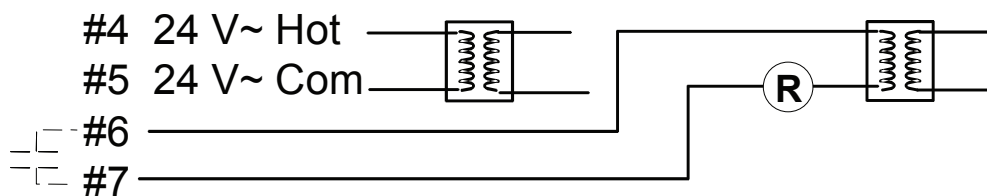

- 24 VAC power to relay

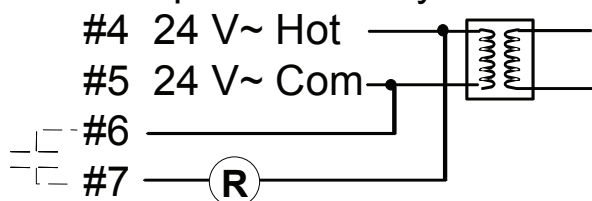

Main outputs wiring

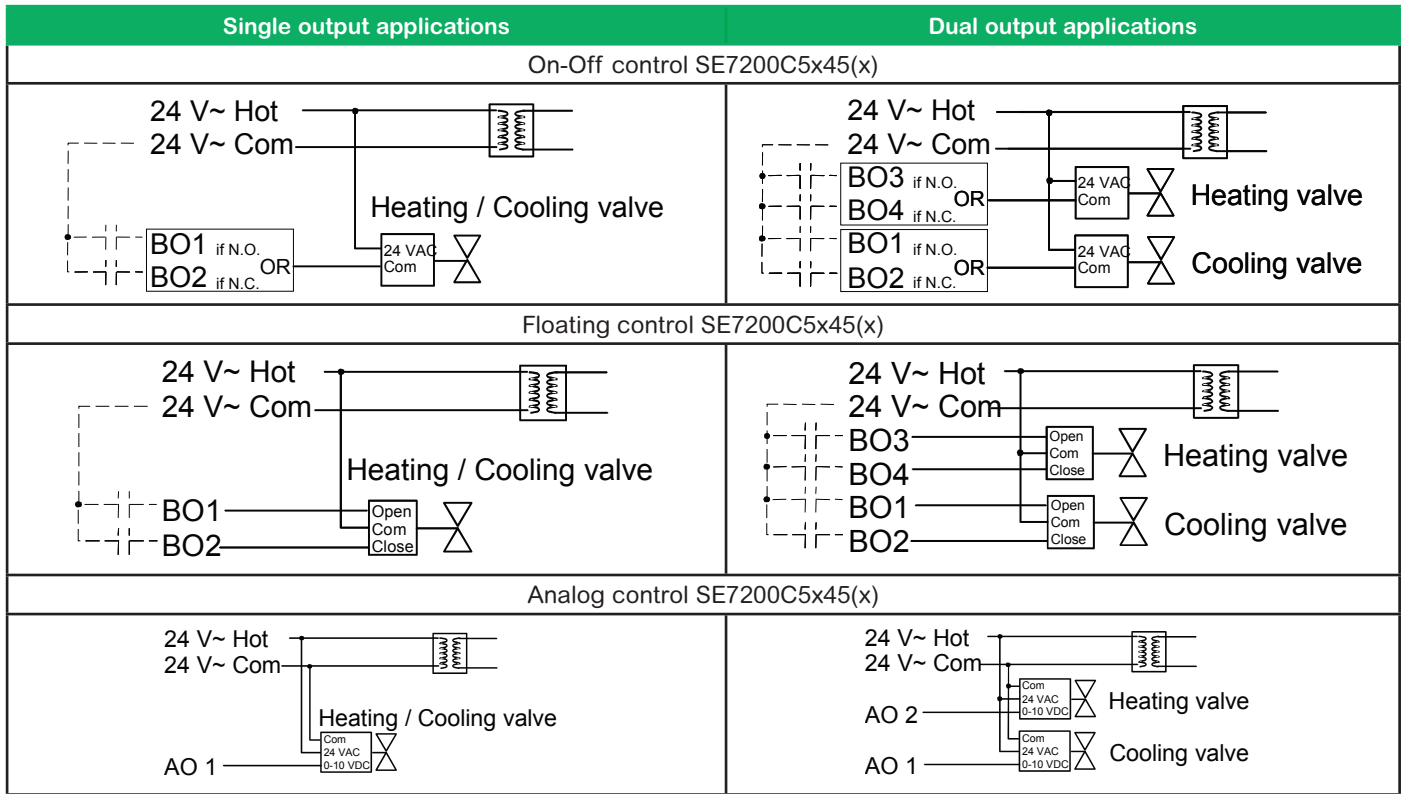

Typical applications

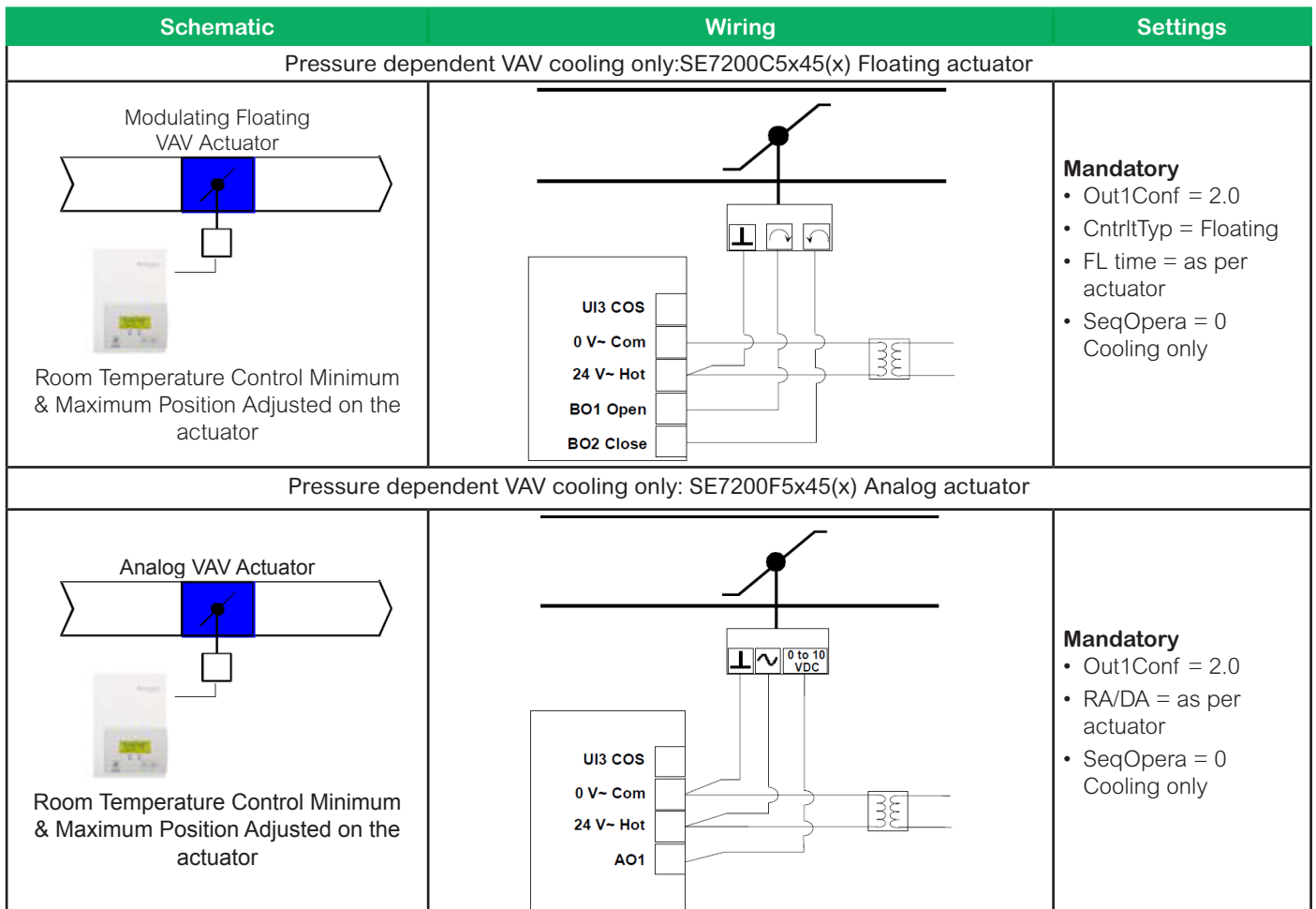

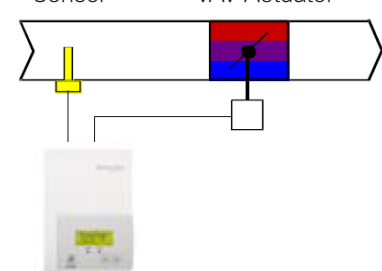
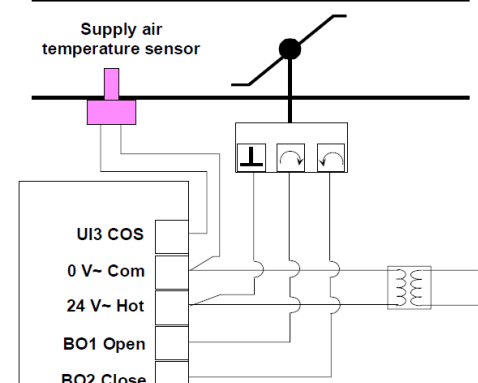
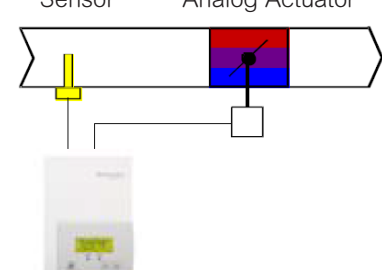
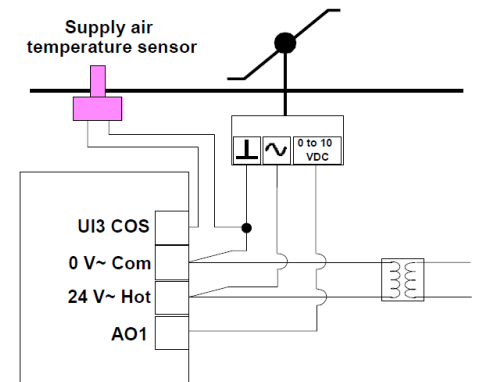
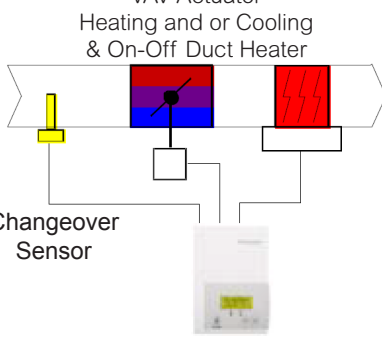
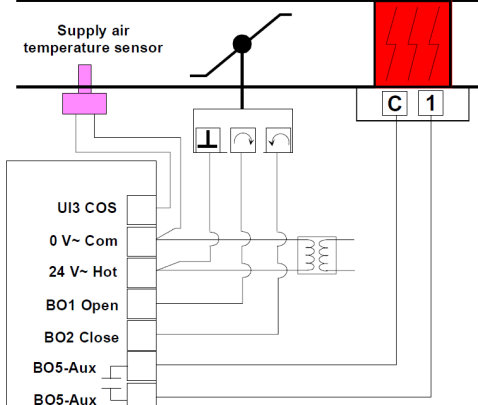
Schematic	Wiring	Settings
<b>Pressure dependent VAV cooling or heating with changeover: SE7200C5x45(x) Floating actuator</b>		
<p>Changeover Sensor      Modulating Floating VAV Actuator</p>  <p>Room Temperature Control Minimum &amp; Maximum Position Adjusted on the actuator</p>		<p><b>Mandatory</b></p> <ul style="list-style-type: none"> <li>• Out1Conf = 2.0</li> <li>• CntrlTyp = Floating</li> <li>• FL time = as per actuator</li> </ul> <p>If <b>heat / cool auto-changeover</b> with a local water temperature sensor set:</p> <ul style="list-style-type: none"> <li>• SeqOpera = 0 Cooling only</li> <li>• UI3 = COS</li> </ul>
<b>Pressure dependent VAV cooling or heating with changeover: SE7200F5x45(x) Analog actuator</b>		
<p>Changeover Sensor      0 to 10 VDC Analog Actuator</p>  <p>Room Temperature Control Minimum &amp; Maximum Position Adjusted on the actuator</p>		<p><b>Mandatory</b></p> <ul style="list-style-type: none"> <li>• Out1Conf = 2.0</li> <li>• RA/DA = as per actuator</li> <li>• SeqOpera = 0 Cooling only</li> </ul> <p>If <b>heat / cool auto-changeover</b> with a local water temperature sensor set:</p> <ul style="list-style-type: none"> <li>• SeqOpera = 0 Cooling only</li> <li>• UI3 = COS</li> </ul>
<b>Pressure dependent VAV cooling or heating with changeover and reheat:SE7200C5x45(x) Floating actuator</b>		
<p>Modulating Floating VAV Actuator Heating and or Cooling &amp; On-Off Duct Heater</p>  <p>Changeover Sensor</p> <p>Room Temperature Control Minimum &amp; Maximum Position Adjusted on the actuator</p>		<p><b>Mandatory</b></p> <ul style="list-style-type: none"> <li>• Out1Conf = 2.0</li> <li>• CntrlTyp = Floating</li> <li>• FL time = as per actuator</li> </ul> <p>If <b>heat / cool auto-changeover</b> with a local water temperature sensor set:</p> <ul style="list-style-type: none"> <li>• SeqOpera = 2 Cooling with Reheat</li> <li>• UI3 = COS</li> </ul>

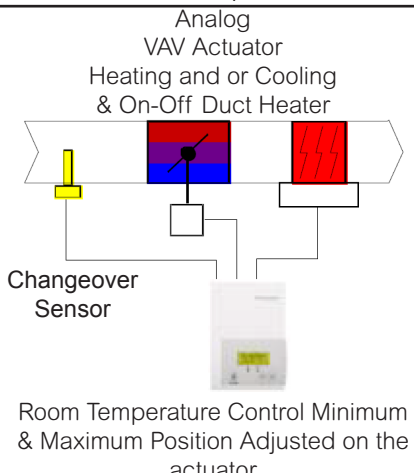
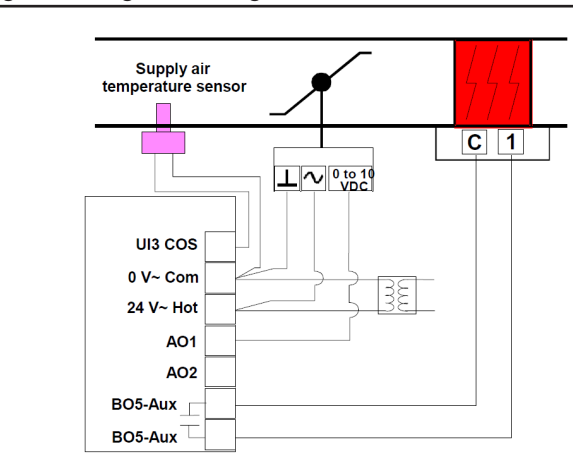
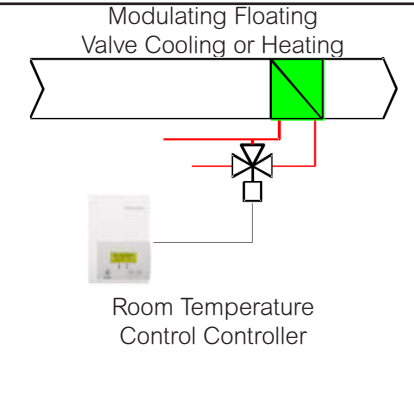
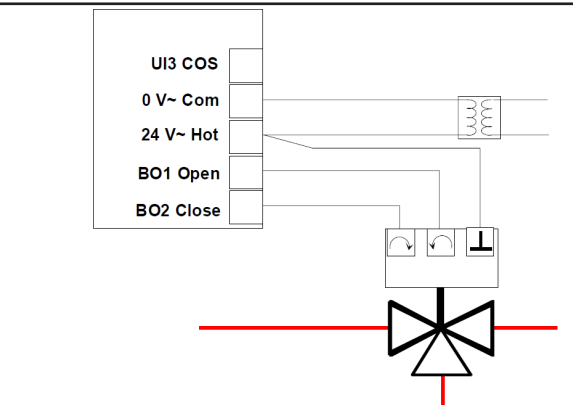
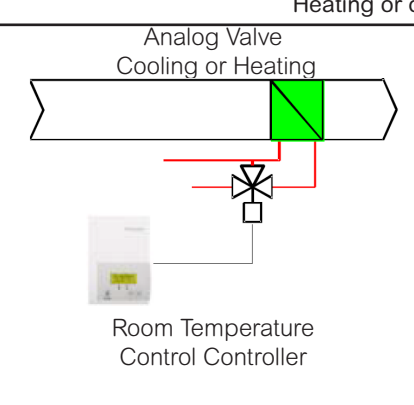
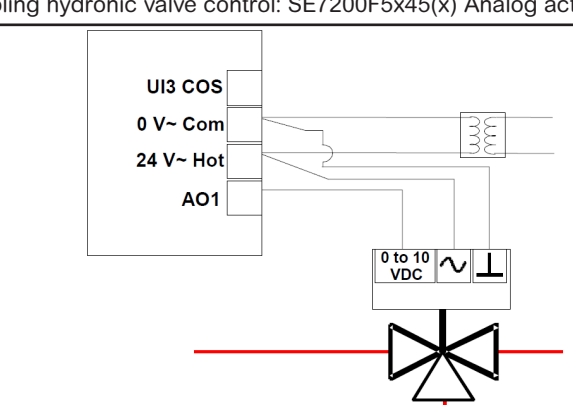
Schematic	Wiring	Settings
<b>Pressure dependent VAV cooling or heating with changeover and reheat: SE7200F5x45(x) Analog actuator</b>		
<p style="text-align: center;">Analog VAV Actuator Heating and or Cooling &amp; On-Off Duct Heater</p>  <p style="text-align: center;">Changeover Sensor</p> <p style="text-align: center;">Room Temperature Control Minimum &amp; Maximum Position Adjusted on the actuator</p>		<p><b>Mandatory</b></p> <ul style="list-style-type: none"> <li>• Out1Conf = 2.0</li> <li>• RA/DA = as per actuator</li> </ul> <p>If <b>heat / cool auto-changeover</b> with a local water temperature sensor set:</p> <ul style="list-style-type: none"> <li>• SeqOpera = 2 Cooling with Reheat</li> <li>• UI3 = COS</li> </ul>
<b>Heating or cooling hydronic valve control: SE7200C5x45(x) Floating actuator</b>		
<p style="text-align: center;">Modulating Floating Valve Cooling or Heating</p>  <p style="text-align: center;">Room Temperature Control Controller</p>		<p><b>Mandatory</b></p> <ul style="list-style-type: none"> <li>• Out1Conf = 2.0</li> <li>• CntrlTyp = Floating</li> <li>• FL time = as per actuator</li> </ul> <p>If <b>cooling only</b> set::</p> <ul style="list-style-type: none"> <li>• SeqOpera = 0 Cooling only</li> </ul> <p>If <b>heating only</b> set::</p> <ul style="list-style-type: none"> <li>• SeqOpera = 1 Heating only</li> </ul>
<b>Heating or cooling hydronic valve control: SE7200F5x45(x) Analog actuator</b>		
<p style="text-align: center;">Analog Valve Cooling or Heating</p>  <p style="text-align: center;">Room Temperature Control Controller</p>		<p><b>Mandatory</b></p> <ul style="list-style-type: none"> <li>• Out1Conf = 2.0</li> <li>• RA/DA = as per actuator</li> </ul> <p>If <b>cooling only</b> set::</p> <ul style="list-style-type: none"> <li>• SeqOpera = 0 Cooling only</li> </ul> <p>If <b>heating only</b> set::</p> <ul style="list-style-type: none"> <li>• SeqOpera = 1 Heating only</li> </ul>

## Cooling or heating with changeover hydronic valve control: SE7200C5x45(x) Floating actuator

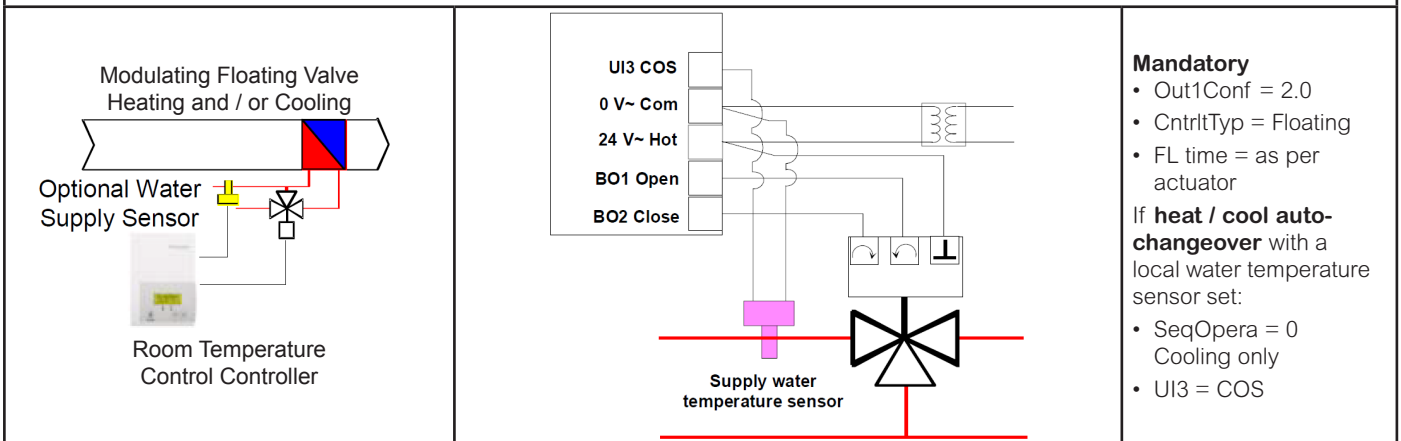

## Cooling or heating with changeover hydronic valve control: SE7200F5x45(x) Analog actuator

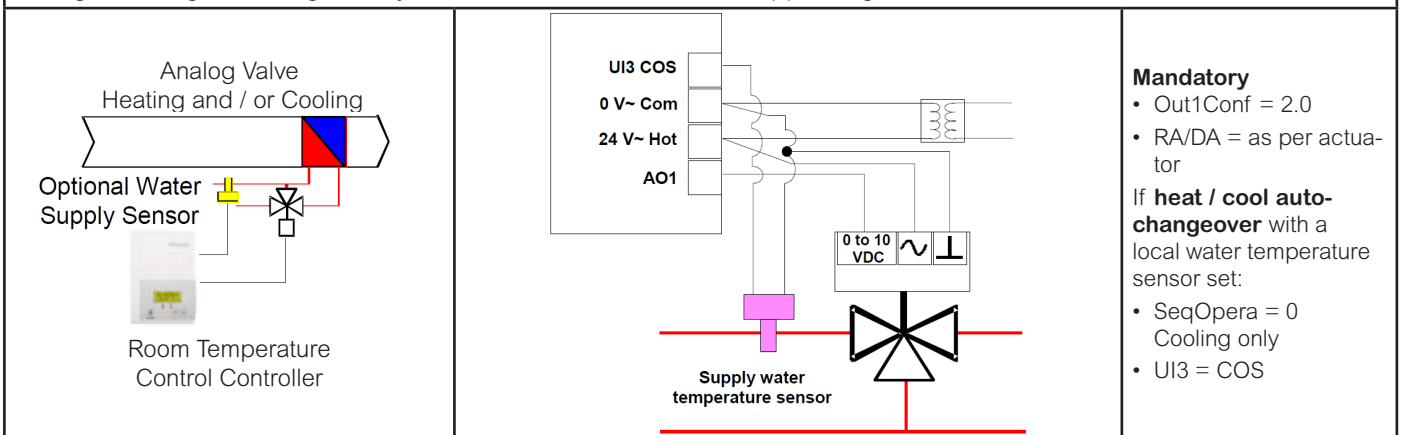

## REMOTE SENSOR ACCESSORIES

Model no.	Description
S3010W1000	Wall mounted temperature sensor
S3020W1045	Wall mounted temperature sensor with override key and occupancy status LED

Remote mount temperature sensors use 10K NTC thermistors.

This sensor can be used for:

- Each sensor can be configured for various averaging combinations
- Optional occupancy led
- Optional override key



S3020W1045

Wall Mounted Sensor

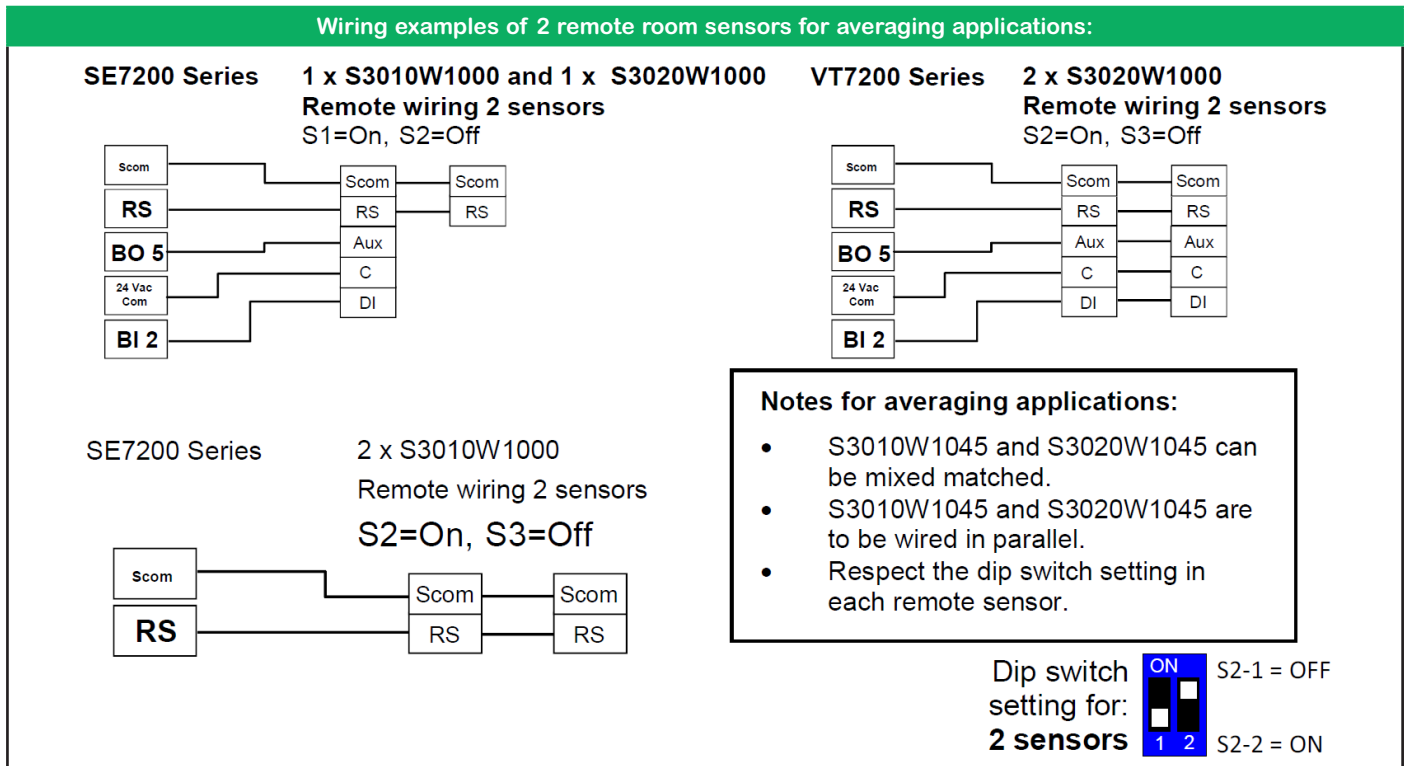
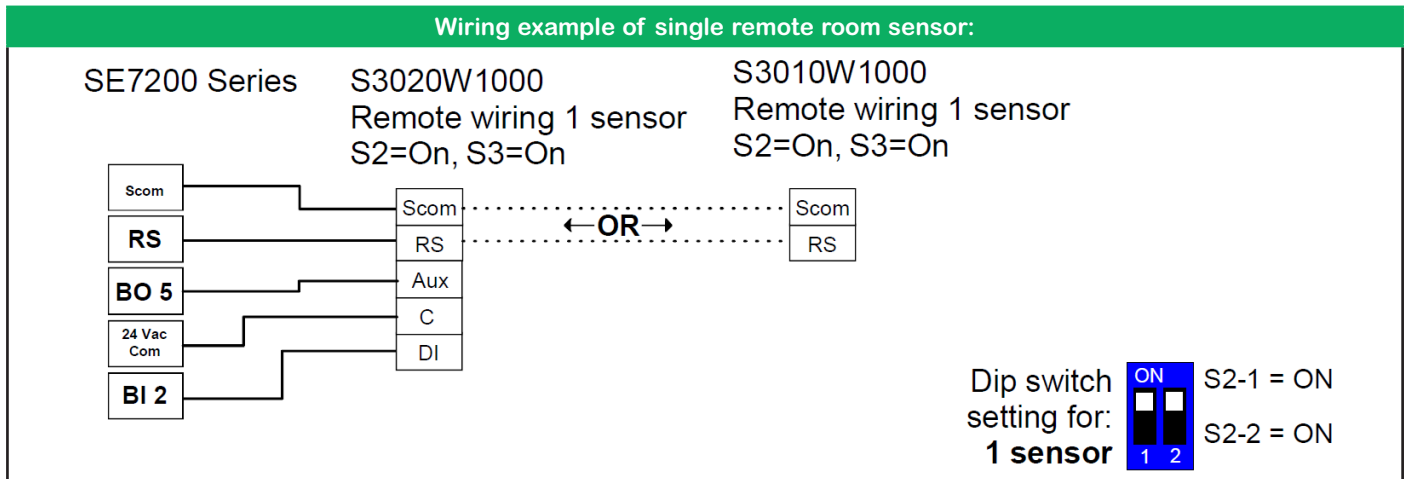

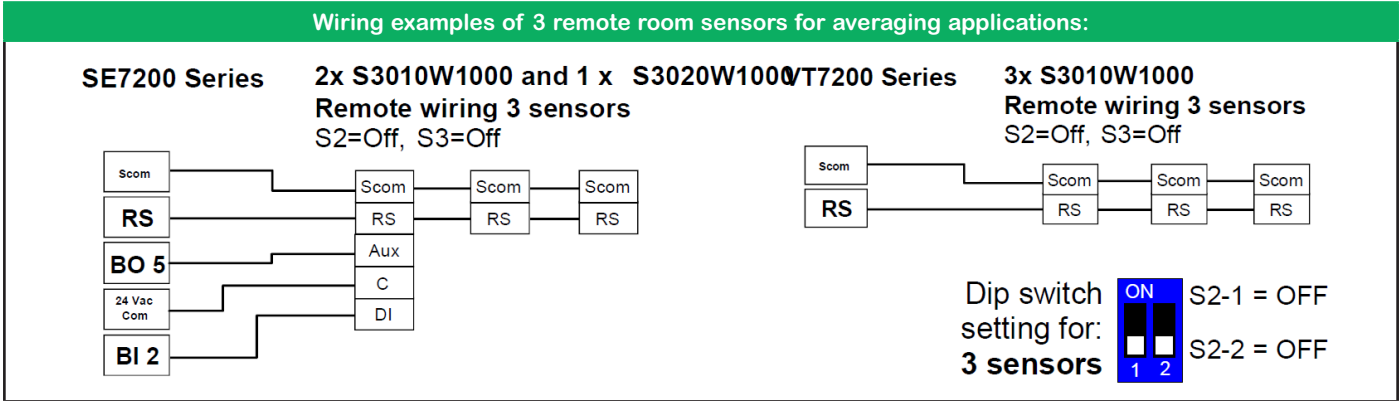

**Temperature vs. resistance chart for 10 Kohm NTC thermistor (R25°C = 10KΩ±3%, B25/85°C = 3975K±1.5%)**

°C	°F	Kohm	°C	°F	Kohm	°C	°F	Kohm	°C	°F	Kohm	°C	°F	Kohm
-40	-40	324.3197	-20	-4	94.5149	0	32	32.1910	20	68	12.4601	40	104	5.3467
-35	-31	234.4009	-15	5	71.2430	5	41	25.1119	25	77	10.0000	45	113	4.3881
-30	-22	171.3474	-10	14	54.1988	10	50	19.7390	30	86	8.0694	50	122	3.6202
-25	-13	126.6109	-5	23	41.5956	15	59	15.6286	35	95	6.5499	55	131	3.0016

## CONFIGURATION AND STATUS DISPLAY INSTRUCTIONS

### Status display

The Room Controller features a two-line, eight-character display. There is a low level backlight level that is always active and can only be seen at night.

When left unattended, the Room Controller has an auto scrolling display that shows the actual status of the system. There is an option in the configuration menu to lockout the scrolling display and to only present the room temperature and conditional outdoor temperature to the user. With this option enabled, no local status is given of mode, occupancy and relative humidity.

Each item is scrolled one by one with the back lighting in low level mode. Pressing any key will cause the back light to come on to high level. When left unattended for 10 seconds after changes are made, the display will resume automatic status display scrolling.

To turn on the back light to high level, press any key on the front panel. The back lit display will return to low level when the Room Controller is left unattended for 45 seconds

Sequence of auto-scroll status display

ROOM & HUMIDITY	SYSTEM MODE	SCHEDULE STATUS	OUTDOOR TEMPERATURE	ALARMS
x.x °C or °F XX % RH	Sys mode	Occupied	Outdoor	Service
	Auto		x.x °C or °F	Filter
	Sys mode cool	Stand-By		Window
	Sys mode heat	Unoccup		

**Outdoor air temperature**

- Display is only enabled when outdoor air temperature network variable is received.

**Occupancy status**

- Occupied, Stand-By, Unoccupied and Override status are displayed on the scrolling display.

**Alarms**

- If alarms are detected, they will automatically be displayed at the end of the scrolling status display.
- When an alarm message is displayed, the backlit screen will illuminate at the same time as the message and shut off during the rest of the status display.
- Two alarms maximum can appear at any given time. The priority for the alarms is as follows:

<b>Service</b>	Indicates that there is a service alarm as per one of the configured binary inputs (BI2)
<b>Filter</b>	Indicates that the filters are dirty as per one of the configured binary inputs (BI2)
<b>Window</b>	Indicates that the outside window or door is opened and that the Room Controller has cancelled any cooling or heating action (BI1)

Two status LED's on the Room Control cover are used to indicate a call for heat or a call for cooling.

**Zoning models**

When <b>heating &amp; reheat</b> is <b>ON</b> , the <b>HEAT LED</b> will illuminate	HEAT O
When <b>cooling</b> is <b>ON</b> , the <b>COOL LED</b> will illuminate	COOL O



## USER INTERFACE

### Unoccupied mode override

An Override can be made during an unoccupied period. If the Override option is enabled in the lockout configuration pressing the Override button will resume occupied setpoints for a time specified by parameter ToccTime .

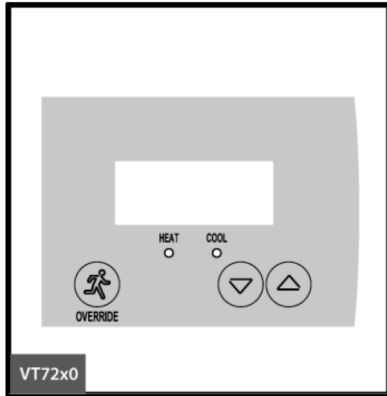
### Local keypad interface



 <p>OVERRIDE</p>	<ul style="list-style-type: none"> <li>An Override can be made during an unoccupied period. If the Override option is enabled in the lockout configuration pressing the override key will resume occupied setpoints for a time specified by parameter ToccTime</li> </ul>
	<ul style="list-style-type: none"> <li>In cooling mode only the cooling setpoint is displayed,</li> <li>In heating mode only the heating setpoint is displayed</li> <li>In auto mode, (See below)</li> </ul>
	<ul style="list-style-type: none"> <li>In cooling mode only the cooling setpoint is displayed,</li> <li>In heating mode only the heating setpoint is displayed</li> <li>In auto mode, (See below)</li> </ul>

- Any setpoint change can be permanent or temporary based on configuration parameter (Setpoint Type)
- Any setpoint written through the network, will be permanent and cancel any active temporary setpoints
- Lockouts of access to certain functions is made with configuration parameter (lockout)

